



ANSI/DASMA 107-2012

---

---

AMERICAN NATIONAL STANDARD

**ROOM FIRE TEST STANDARD FOR  
GARAGE DOORS USING FOAM  
PLASTIC INSULATION**

---

---

---

ANSI/DASMA 107-2012

Door & Access Systems Manufacturers' Association, International

---

Sponsor:



1300 Sumner Ave  
Cleveland, Ohio 44115-2851

AMERICAN NATIONAL STANDARD  
**Room Fire Test Standard for Garage Doors Using  
Foam Plastic Insulation**

Sponsor

**Door & Access Systems Manufacturers' Association, International**

# American National Standard

American National Standard implies a consensus of those substantially concerned with its scope and provisions. An American National Standard is intended as a guide to aid the manufacturer, the consumer, and the general public. The existence of an American National Standard does not in any respect preclude anyone, whether he has approved the standard or not, from manufacturing, marketing, purchasing or using products, processes, or procedures not conforming to the standard. American National Standards are subject to periodic review and users are cautioned to obtain the latest editions.

## **CAUTION NOTICE:**

This American National Standard may be revised or withdrawn at any time. The procedures of the American National Standards Institute require that action be taken to reaffirm, revise, or withdraw this standard no later than five years from the date of publication. Purchasers of American National Standards may receive current information on all standards by calling or writing the American National Standards Institute.

Sponsored and published by:  
DOOR & ACCESS SYSTEMS MANUFACTURERS'  
ASSOCIATION, INTERNATIONAL  
1300 Sumner Avenue  
Cleveland, OH 44115-2851  
Phn: 216/241-7333  
Fax: 216/241-0105  
E-Mail: [dasma@dasma.com](mailto:dasma@dasma.com)  
URL: [www.dasma.com](http://www.dasma.com)

Copyright © 2012 by Door & Access Systems Manufacturers'  
Association, International  
All Rights Reserved

No part of this publication may be reproduced in any form, in an electronic retrieval system or otherwise, without the prior written permission of the publisher.

Suggestions for improvement of this standard will be welcome. They should be sent to the Door & Access Systems Manufacturers' Association, International.

Printed in the United States of America

# CONTENTS

PAGE

<b>Foreword</b> .....	v
1. Scope .....	1
2. Significance and Use .....	1
3. Summary of Method .....	1
4. Definitions .....	2
5. Ignition Source .....	2
6. Compartment Geometry and Construction .....	2
7. Specimen Mounting .....	2-3
8. Specimen Conditioning .....	3
9. Environmental Conditions .....	3
10. Instrumentation .....	3-5
11. Calibration .....	5-6
12. Test Procedure .....	6-7
13. Calculations .....	7-9
14. Test Report .....	9-10
15. Acceptance Criteria .....	10

## Figures

Figure 1 - Gas Burner .....	11
Figure 2 - Burner Location and Specimen Mounting Details .....	12
Figure 3 - Gas Flow Regulation Systems .....	13
Figure 4 - Interior Room and Doorway Dimensions .....	14
Figure 5 - Angle Brackets .....	15
Figure 6 - Thermocouple and Calorimeter Placement .....	16
Figure 7 - Canopy Hood and Exhaust Duct .....	17
Figure 8 - Plain View of Canopy Hood .....	18
Figure 9 - Bi-directional Probe .....	19
Figure 10 - Optical System, Using a White Light .....	20
Figure 11 - Paper Target Arrangement - Plain View .....	21

**Foreword** (This foreword is included for information only and is not part of ANSI/DASMA 107, *Room Fire Test Standard for Garage Doors Using Foam Plastic Insulation.*)

This standard was developed by the Commercial & Residential Garage Door Division of the Door & Access Systems Manufacturers' Association, International, (DASMA). DASMA was formed through the consolidation of two associations that served the garage door and operator industries for many years, the National Association of Garage Door Manufacturers (NAGDM) and the Door Operator and Remote Control Manufacturers Association (DORCMA).

The NAGDM Technical Committee, now the Technical Committee of the Commercial & Residential Garage Door Division, began to explore the need to develop a test method for foam plastic insulated garage doors in 1994. The committee identified a representative sample of the most common types of garage doors and foam plastic insulations. The committee also developed a proposed test method specifically for garage doors. This method was based on a room/corner test method that had been developed for wall coverings and used the latest advances in fire testing.

Using the representative sample that had been identified, the committee conducted a number of tests to evaluate the method and the performance of the garage doors. Minor revisions were made to the method and the committee prepared a draft standard. The draft was approved as a NAGDM standard in late 1995. The DASMA Commercial & Residential Garage Door Division sought approval of the standard as an American National Standard, using the canvass process to demonstrate consensus, in 1996. The ANSI Board of Standards Review approved the standard as an American National Standard on June 19, 1997. The ANSI Board of Standards Review reaffirmed approval as an American National Standard on October 27, 2004, and the ANSI Board of Standards Review approved the revised standard on June 15, 2012.

DASMA recognizes the need to periodically review and update this standard. Suggestions for improvement should be forwarded to the Door & Access Systems Manufacturers' Association, International, 1300 Sumner Avenue, Cleveland, Ohio, 44115-2851.

# ANSI/DASMA 107-2012

## AMERICAN NATIONAL STANDARD

### Room Fire Test Standard for Garage Doors Using Foam Plastic Insulation

#### 1.0 SCOPE

1.1 This standard is a test method designed to evaluate the contribution of garage doors using foam plastic insulation to the creation of fire hazard under specified fire exposure conditions. The method is conducted in a standard room configuration.

1.2 This standard is to be used to evaluate the flammability characteristics of garage door assemblies using foam plastic insulation when the foam plastic is not separated from occupied spaces by a facing of minimum 0.3 mm (0.010 in.) steel or 3.2 mm (1/8 in.) wood.

1.3 This standard is not intended to evaluate the fire endurance of assemblies, nor does it provide full information concerning the toxicity of combustion gases.

#### 2.0 SIGNIFICANCE AND USE

2.1 This fire test measures fire performance characteristics of foam plastic insulated garage doors in an enclosure when the test specimen is subjected to a specified flaming ignition source under well ventilated conditions.

2.2 The method determines the extent to which foam plastic insulated garage doors contribute to the creation of fire hazard in a room under the conditions specified. The method also assesses the potential for fire spread beyond the room under the particular conditions simulated.

2.3 The test indicates the maximum extent of fire growth in a room, the rate of heat release, smoke obscuration, flame propagation tendencies, and, if they occur, the time to flashover and the time for flame extension beyond the doorway.

2.4 The effect of the fire on objects in or near the room, but remote from the ignition source, is evaluated by measurements of:

- ① The total heat flux incident on the center of the floor.
- ② The upper level gas temperature in the room.
- ③ The instantaneous peak rate of heat release.

2.5 The effects of the fire on areas remote from the room of origin is evaluated mainly by the measurement of total heat release of the fire.

2.6 Rate of heat release is measured by the principle of oxygen consumption. Measurements of the rate of production of carbon monoxide and carbon dioxide are normally taken. Where carbon dioxide and/or carbon monoxide is "scrubbed" and therefore not measured, Section 13 provides alternative calculation methods for rate of heat release.

2.7 Smoke obscuration is measured by an optical system within the fire room exhaust duct. Smoke obscuration measurement (as the rate of smoke release, total smoke released or the optical density of the smoke) is used to estimate the reduction in visibility caused by the smoke released during a test.

#### 3.0 SUMMARY OF METHOD

3.1 A 2.13 m (7 ft.) high x 2.4 m (8 ft.) wide foam plastic insulated garage door is mounted adjacent to the rear wall of a 2.4 m (8 ft.) wide, 3.6 m (12 ft.) long x 2.4 m (8 ft.) high room enclosure. The test specimen covers the rear wall from floor level to 2.13 m (7 ft.) high.

3.2 This method uses a gas burner to produce a diffusion flame. The burner is located in the corner of the test room adjacent to the test specimen. The burner produces a prescribed rate of heat release output of 40 kW (38 Btu/s) for 5 minutes followed by 150 kW (142 Btu/s) for 10 minutes, for a total exposure period of 15 minutes. The contribution of the test specimen to room fire hazard is measured via constant monitoring of the rate of heat release, smoke release rate, the temperature of the gases in the upper part of the room, temperature rise in the core of the test sample, incident heat flux on the center of the floor and time to flashover. The test is conducted with natural ventilation to the room provided by a single doorway 0.76 m (30 in.) wide x 2.03 m (80 in.) high.

3.3 The combustion products are collected in a hood feeding into a plenum connected to an exhaust duct in which measurements are made of the gas velocity, temperature, percent light transmission, and concentration of selected gases.

## 4.0 DEFINITIONS

For purposes of this standard, the following terms shall be defined as indicated:

### 4.1 Average Upper Gas Layer Temperature.

This temperature shall be based on the average of the four ceiling quadrant thermocouples and the center of the room ceiling thermocouple.

4.2 Flashover. Flashover shall be determined to have occurred when any two of the following conditions have been attained:

- ① Heat flux at floor reaches  $25 \text{ kW/m}^2$  ( $2.2 \text{ Btu/ft}^2\text{-s}$ )
- ② Average upper air temperature exceeds  $650^\circ\text{C}$  ( $1200^\circ\text{F}$ )
- ③ Flames exit doorway
- ④ Spontaneous ignition of paper target on floor occurs.

## 5.0 IGNITION SOURCE

5.1 Burner Dimensions. The ignition source for the test shall be a gas burner with a nominal  $0.3 \text{ m} \times 0.3 \text{ m}$  ( $12 \text{ in.} \times 12 \text{ in.}$ ) porous top surface of refractory material. See Figure No. 1. A burner shall be constructed with a  $25.4 \text{ mm}$  ( $1 \text{ in.}$ ) thick porous ceramic fiberboard over a  $152 \text{ mm}$  ( $6 \text{ in.}$ ) plenum, or a minimum  $102 \text{ mm}$  ( $4 \text{ in.}$ ) layer of Ottawa sand shall be permitted to be used to provide the horizontal surface through which the gas is supplied.

5.2 Burner Location. The top surface of the burner through which the gas is applied shall be  $0.3 \text{ m}$  ( $12 \text{ in.}$ ) above the floor in the left rear corner of the room as viewed from the door. The burner enclosure shall be located such that the edge of the diffusion surface is located  $51 \text{ mm}$  ( $2 \text{ in.}$ ) from the left side wall and  $51 \text{ mm}$  ( $2 \text{ in.}$ ) from the facing over the foam plastic core of the test specimen. See Figure No. 2.

5.3 Burner Gas Supply. The gas supply to the burner shall be of C.P. grade propane (99 percent purity) or methane. The burner shall be capable of producing a gross heat output of  $40 \text{ kW} \pm 1 \text{ kW}$  ( $38 \text{ Btu/s} \pm 1 \text{ Btu/s}$ ) for 5 minutes followed by a gross heat output of  $150 \text{ kW} \pm 5 \text{ kW}$  ( $142 \text{ Btu/s} \pm 5 \text{ Btu/s}$ ) for 10 minutes. Heat release rates shall be calculated using propane's net heat of combustion, which is  $46.5 \text{ MJ/kg}$  or methane's net heat of combustion which is  $50.0 \text{ MJ/kg}$ . The burner design shall allow switching from  $40 \text{ kW}$  ( $38 \text{ Btu/s}$ ) to  $150 \text{ kW}$  ( $142 \text{ Btu/s}$ ) within 10 seconds. Burner controls are permitted for automatic shutoff of the gas supply if flameout

occurs. Two acceptable arrangements for a gas supply are illustrated by Figure No. 3.

5.4 Burner Ignition. The burner shall be ignited by a pilot burner or a remotely controlled ignitor.

## 6.0 COMPARTMENT GEOMETRY AND CONSTRUCTION

6.1 Fire Room Dimensions. The interior dimensions of the floor of the fire room, when the specimens are in place, shall measure  $2.44 \text{ m} \pm 0.1 \text{ m} \times 3.66 \text{ m} \pm 0.1 \text{ m}$  ( $8 \text{ ft.} \pm 3.9 \text{ in.} \times 12 \text{ ft.} \pm 3.9 \text{ in.}$ ). The finished ceiling shall be  $2.44 \pm 0.1 \text{ m}$  ( $8 \text{ ft.} \pm 3.9 \text{ in.}$ ) above the floor. There shall be four walls at right angles defining the compartments. See Figure No. 4.

6.2 Doorway. There shall be a  $0.76 \text{ m} \pm 6.4 \text{ mm} \times 2.03 \text{ m} \pm 6.4 \text{ mm}$  ( $30 \text{ in.} \pm 0.25 \text{ in.} \times 80 \text{ in.} \pm 0.25 \text{ in.}$ ) doorway in the center of one of the  $2.44 \text{ m} \times 2.44 \text{ m}$  ( $8 \text{ ft.} \times 8 \text{ ft.}$ ) walls, and there shall be no other wall, floor, or ceiling openings that allow ventilation. The door frame shall be constructed to remain unchanged during the test period to a tolerance of  $\pm 1$  percent in height and width.

6.3 Fire Room Construction. The fire room shall be permitted to be a framed or a masonry structure. The floor, ceiling, and walls of the test compartment shall be covered by calcium silicate board or by gypsum wallboard. The inside surface of the wall containing the door shall be of calcium silicate board of  $736 \text{ kg/m}^3$  ( $46 \text{ lb/ft}^3$ ) density and  $12 \text{ mm}$  ( $0.5 \text{ in.}$ ) in nominal thickness or  $12 \text{ mm}$  ( $0.5 \text{ in.}$ ) gypsum wallboard.

## 7.0 SPECIMEN MOUNTING

Specimen mounting details shall be comparable to that intended for actual product use. Specimens shall consist of full garage door assemblies incorporating inside and outside facings, gaskets, framing members, insulation, air gaps, and other details, as appropriate to the product being evaluated, and as follows:

7.1 A minimum  $2.4 \text{ m}$  ( $8 \text{ ft.}$ ) wide  $\times$   $2.13 \text{ m}$  ( $7 \text{ ft.}$ ) high test specimen shall be mounted adjacent to the gypsum wallboard rear wall of the fire room enclosure, as shown in Figure No. 2.

7.2 The garage door shall be mounted in the fire room so that the bottom of the door rests on the floor of the fire room and the top of the door is not more than  $305 \text{ mm}$  ( $12 \text{ in.}$ ) below the underside of the ceiling. Where a garage door in an actual installation may be installed with less than  $305 \text{ mm}$  ( $12 \text{ in.}$ )



separation between the top of the door and the underside of the ceiling, the door shall be mounted in the fire room using the minimum separation contemplated for the actual installation.

7.3 Test specimens are attached to the gypsum wallboard fire room enclosure using metal stud screws and fender washers at the edges of panels as indicated on Figure No. 2. Angle brackets are located at panel edges, so that one bracket attaches to, and secures, two panels in place. See Figure No. 5. The screws and angle brackets located directly above the burner are tightened to hold the test specimen securely in place. The angle bracket and metal stud screws placed in the slots of the angle bracket on the end of the panels remote from the burner are lightly tightened, allowing the specimen to expand during tests. The right side of the test specimen, as viewed from the room door, is to be separated up to a maximum of 38.1 mm (1 1/2 in.) from the right side wall of the test room enclosure to allow for thermal expansion.

7.4 Test specimens are oriented such that the normally inside face of the garage door assembly faces the burner.

## 8.0 SPECIMEN CONDITIONING

Prior to testing, specimens shall be conditioned for a minimum of seven days or until the sample reaches a rate of weight change of less than 0.1 percent per day at a temperature of  $49^{\circ}\text{C} \pm 2.8^{\circ}\text{C}$  ( $70^{\circ}\text{F} \pm 5^{\circ}\text{F}$ ) and a relative humidity of 50 percent  $\pm$  5 percent.

## 9.0 ENVIRONMENTAL CONDITIONS

9.1 Fire Room Air Supply. The building in which the fire room is located shall have vents for the discharge of combustion products and have provision for fresh air intake, so that no oxygen deficient air is introduced into the fire room during the test. Prior to the start of the test, the ambient air at the mid-height entrance to the fire room shall have a velocity of less than 0.5 m/sec (100 ft/min.) in any direction. The building shall be of adequate size so that there shall be no smoke accumulation in the building below the level of the top of the fire room.

9.2 Ambient Temperature. The ambient temperature in the test building around the fire room shall be above  $4^{\circ}\text{C}$  ( $40^{\circ}\text{F}$ ) and the relative humidity shall be less than 75 percent for the duration of the test.

9.3 Ambient Conditions. If test samples are installed within the fire room for two or more hours prior to test, the following ambient conditions shall be maintained:

9.3.1 The ambient temperature in the fire room measured by one of the thermocouples specified in 26.810.2(3) shall be  $18^{\circ}\text{C}$  to  $24^{\circ}\text{C}$  ( $65^{\circ}\text{F}$  to  $75^{\circ}\text{F}$ ).

9.3.2 The ambient relative humidity in the fire room shall be 50 percent  $\pm$  5 percent.

## 10.0 INSTRUMENTATION

The following instrumentation shall be provided for this test:

### 10.1 Total Heat Flux Gauge.

10.1.1 Location. A gauge shall be mounted a maximum of 51 mm (2 in.) above the floor surface, facing upward in the geometric center of the fire room. See Figure No. 6.

10.1.2 Specification. The gauge shall be of the Gardon or Schmidt-Boetler type, with a circular flat black surface of 13 mm (1/2 in.) diameter and a  $180^{\circ}$  view angle. In operation, it shall be maintained at a constant temperature within  $2.8^{\circ}\text{C}$  ( $\pm$  5 percent  $^{\circ}\text{F}$ ) above the dewpoint by water supplies at a temperature of  $50^{\circ}\text{C}$  to  $65^{\circ}\text{C}$  ( $120^{\circ}\text{F}$  to  $150^{\circ}\text{F}$ ). This will normally require a flow rate of at least .38 L/min. (0.1 gal/min.). The full scale output range shall be  $50 \text{ kW/m}^2$  for the gauge.

### 10.2 Thermocouples.

10.2.1 Specification. Bare Type K thermocouples, 0.5 mm (20 mil) in diameter, shall be used at each required location. The thermocouple wire within 13 mm (0.5 in.) of the bead shall be run along expected isotherms to minimize conduction errors. The insulation between the chromel and alumel wires shall be stable to at least  $1100^{\circ}\text{C}$  ( $2000^{\circ}\text{F}$ ), or the wires shall be separated.

10.2.2 Location in Doorway. A thermocouple shall be located in the interior plane of the door opening on the door centerline, 100 mm (4 in.) from the top. See Figure No. 6.

10.2.3 Location in Room. Thermocouples shall be located 100 mm (4 in.) below the ceiling, at the center of the ceiling, at the center of each of the four ceiling quadrants, and directly over the center of the ignition burner. The thermocouples shall be mounted on supports or penetrate through the ceiling with their junctions 100 mm (4 in.) away from a solid surface. See Figure No. 6. Any ceiling penetration shall be just large enough to permit passage of the thermocouples. Spackling compound or ceramic

fiber insulation shall be used to backfill the holes around the thermocouple wire.

10.2.4 Location in Canopy and Exhaust Duct. One pair of thermocouples shall be placed a minimum of 8.25 duct diameters downstream of the entrance to the horizontal duct. The pair of thermocouples shall straddle the center of the duct and be separated 50 mm (2 in.) from each other. See Figure No. 7.

10.2.5 Location in Specimen Foam Core. One thermo-couple shall be placed near the center of the foam plastic core, approximately 76.2 mm (3 in.) from the right side and 330 mm (13 in.) below the ceiling of the fire room. See Figure No. 2.

### 10.3 Canopy Hood and Exhaust Duct.

10.3.1 Location and Design. A hood shall be installed immediately adjacent to the door of the fire room. The bottom of the hood shall be level with the top surface of the room. The face dimensions of the hood shall be a minimum of 2.44 m x 2.44 m (8 ft. x 8 ft.) and the minimum depth shall be 1.1 m (3.5 ft.). The hood shall feed into a plenum having a minimum 0.92 m x 0.92 m (3 ft. x 3 ft.) cross section. The plenum shall have a minimum height of 0.92 m (3 ft.). This height shall be permitted to be increased to a maximum of 1.8 m (6 ft.) to satisfy building constraints. The exhaust duct connected to the plenum shall be a minimum of 0.4 m (16 in.) in diameter, horizontal, and shall be permitted to have a circular aperture of at least 0.3 m (12 in.) at its entrance or mixing vanes in the duct. See Figure Nos. 7 and 8 for additional details.

10.3.2 Exhaust Flow Rate. The hood shall have sufficient draft to collect all of the combustion products leaving the room. This draft shall be capable of moving up to 3.4 m<sup>3</sup>/sec (7000 standard ft<sup>3</sup>/min.) equivalent to 7.25 m<sup>3</sup>/s (16,100 cfm) at 399°C (750°F) during the test. Provision shall be made so that the draft can operate at 0.47 to 3.4 m<sup>3</sup>/sec (1000 to 7000 standard ft<sup>3</sup>/min.). Mixing vanes shall be provided in the duct if concentration gradients are found to exist.

10.3.3 Alternative Exhaust Design. An alternative exhaust system design shall be permitted to be used if it meets the requirements of Section 11.

### 10.4 Duct Gas Velocity.

10.4.1 Specification. A bi-directional probe or an equivalent measuring system shall be used to measure gas velocity in the duct. The probe shall consist of a short, stainless steel cylinder 44 mm (1.75 in.) long and of 22 mm (0.875 in.) inside diameter with a solid diaphragm in the center or

other design shown capable of measuring gas velocity in the duct. See Figure No. 9. The pressure taps on either side of the diaphragm support the probe. The axis of the probe shall run along the centerline of the duct a minimum of 8.25 duct diameters downstream from the entrance. See Figure No. 7. The taps shall be connected to a pressure transducer that shall be able to resolve pressure differences of 0.25 Pa (0.001 in. H<sub>2</sub>O).

### 10.5 Oxygen Depletion Measurements.

10.5.1 Determination of Rate of Heat Release. A stainless steel gas sampling tube shall be located a minimum of 8.63 duct diameters downstream from the entrance to the duct at the geometric center of the duct,  $\pm 13$  mm ( $\pm 1/2$  in.), to obtain a continuously flowing sample for determining the oxygen concentration of the exhaust gas as a function of time. See Figure No. 7. A suitable filter and cold trap shall be placed in the line ahead of the analyzer to remove particulates and water. The oxygen analyzer shall be of the paramagnetic or polarographic type and shall be capable of measuring oxygen concentration in a range of 21 percent to 15 percent, with a relative accuracy of 50 ppm in this concentration range. The signal from the oxygen analyzer shall be within 5 percent of its final value and occur within 30 sec. of introducing a step change in composition of the gas stream flowing past the inlet to the sampling tube.

10.5.2 Duct Carbon Dioxide Concentration. The gas sampling tube, described in Paragraph 10.5.1 above, shall be used to provide a continuous sample for the measurement of the carbon dioxide concentration using an analyzer with a range of 0 to 20 percent, with a maximum relative error of 2 percent of full scale. The total system response time between the sampling inlet and the meter shall be no longer than 30 seconds.

10.5.3 Duct Carbon Monoxide Concentration. The gas sampling tube, defined in Paragraph 10.5.1 above, shall be used to provide a continuous sample for the measurement of the carbon monoxide concentration using an analyzer with a range of 0 to 10 percent, with a maximum relative error of 2 percent of full scale. The signal from the analyzer shall be within 5 percent of its final value and occur within 30 sec. after introducing a step change in composition of the gas stream flowing past the inlet to the sampling tube.

### 10.6 Smoke Obscuration Measurement

10.6.1 Optical System. An optical system for measurement of light obscuration across the centerline of the exhaust duct shall be provided and

shall be located a minimum of 9 duct diameters downstream from the entrance to the duct. See Figure No. 7. The optical density of the smoke shall be determined by measuring the light transmitted across the centerline of the exhaust duct with a photometer system consisting of a white light source and a photocell/detector or a laser system.

10.6.2 Specifications. The optical system shall consist of a lamp, plano convex lenses, an aperture, a photocell, and an appropriate power supply. The lenses, lamp, and photocell shall be mounted inside two housings, located on the exhaust duct, diametrically opposite each other. The system shall be constructed such that soot deposits on the optics during a test do not reduce the light transmission by more than 5 percent.

10.6.3 Lamp. A lamp of the incandescent filament type, which operates at a color temperature of  $2,900 \pm 100$  K, shall be used. Supply the lamp with stabilized direct current, stable within  $\pm 0.2\%$  (including temperature, short term and long term stability). Center the resultant light beam on the photocell.

10.6.4 Lens System. Select the lens system such that lens L2 has a diameter,  $d$ , chosen with regard to the focal length,  $f$ , of L2 so that  $d/f \geq 0.04$ . Place the aperture in the focus of lens L2. See Figure No. 10.

10.6.5 Detector. Use a detector with a spectrally distributed response according to the CIE photopic curve and linear within 5% over an output range of at least 3.5 decades. Check this linearity over the entire range of the instrument periodically with calibrated optical filters.

10.6.6 Optical System. Optical system design shall be one that is purged easily against soot deposits. Holes shall be provided in the periphery of the two housings as a means of achieving this objective.

10.7 Paper Targets. Two paper target flashover indicators shall be placed on the floor of the test room - see Figure No. 11. The targets shall consist of a single piece of newsprint crumpled into an approximate 152 mm (6 in.) diameter ball.

10.8 Photographic Documentation. Photographic or video equipment shall be used to record the fire spread in the fire room and the fire projection from the door of the room. The location of the cameras shall avoid interference with airflow. The interior wall surfaces of the fire room adjacent to the corner in which the burner is located shall be clearly marked. A clock shall appear in all photographic records, showing the time to at least the nearest 1 sec.

from the start of the test. This clock shall be accurately synchronized with all other measurements, or other provision shall be made to correlate the photo record with time. Color slides or photographs shall be taken at intervals for the duration of the test, or a continuous video recording shall be made.

## 11.0 CALIBRATION

11.1 Heat Release, Temperature, and Velocity. A calibration test shall be performed prior to and within 30 days of any fire test. The calibration test shall last for a minimum of 10 minutes. Take measurements a minimum of once every six seconds. The standard ignition source shall be used with inert wall and ceiling materials - calcium silicate board of  $736 \text{ kg/m}^3$  ( $56 \text{ lb/ft}^3$ ) density, 13 mm (0.50 in.) thickness, or gypsum wallboard.

11.1.1 Calibration Factor. The data resulting from a calibration test shall provide:

- a. The output as a function of time, after the burner is activated, of all instruments normally used for the standard fire test.
- b. The maximum extension of the burner flame, as recorded by still photographs taken at approximately 30 second intervals or continuous video recording.
- c. Calculation of C factor when either an orifice plate or bi-directional probe is used: The C factor in Eq. (4) shall be determined in accordance with the following. Place the sand burner in the room/corner. Set the methane or propane flow to provide a constant heat release rate of 150 kW. Ignite the gas, and continue the burner for 10 minutes, and then switch off the gas. Then calculate the C factor as follows:
  - i. Estimate the initial calibration constant for C using the product 22.1 A, where "A" is the area of the duct (in  $\text{m}^2$ ). This gives a good estimation (generally within about 20 percent) of the final value one can expect for "C".
  - ii. Burn either propane or methane fuel at 150 kW for a 10 minute interval. Measure the heat release rate using oxygen consumption calorimetry, and Equation 3 using E and  $\alpha$  values appropriate to the fuel. See E and  $\alpha$  values contained within the list of defined symbols.
  - iii. Calculate the total heat released from the mass loss of fuel and its heat

of combustion, as specified in the standard (e.g. 1.8 kg of methane consumed = 90,000 kJ).

iv. Adjust the calibration constant “C” so that the total rate of heat released, as determined by the oxygen consumption calculation, agrees with that from the mass of fuel consumed to within 5 percent.

$$C_{new} = \left[ \frac{A(MJ/kg) * B(kg) * 1000(kJ/MJ)}{\int_0^T q(t) dt (kJ)} \right] * C_{old}$$

Where: A is the fuel value of the fuel being used and B is the total weight of fuel burned in the period T.

v. Use the new constant for subsequent tests for calculation of HRR and volumetric flow rate as in the example that follows.

Example: An initial value of 6.6 is assigned to C. A 10 minute calibration burn uses 1.8 kg of methane (50 MJ/kg) at a fuel flow rate that corresponds to 150 kW. The oxygen consumption calculations reveal an average HRR of 160 kW during the burn period. Integrating the HRR curve over the 10 minute burn period shows that the total heat measured is 96,000 kJ. Applying the equation above, one finds

$$C_{new} = [0.94] * C_{old}$$

The new calibration constant is 6.2. This will adjust the measured HRR (and THR) so that it agrees with the heat released from the fuel burned. Use the new calibration constant in all subsequent tests up until a new calibration burn is performed.

11.1.2 Calculated Heat Release. The total rate of heat production as determined by the oxygen consumption calculation, independent measurement of the volumetric flow rate and, weight loss of propane or methane supply shall agree to within 5 percent. The net heat of combustion is 46.5 MJ/kg for propane and 50.0 MJ/kg for methane. This value shall be used for this calculation.

11.2 Smoke Obscuration. The smoke meter shall be calibrated to read correctly for two neutral density filters at 0.5 and 1.0 values of optical density and also at 100% transmission. The 0 value of extinction coefficient (100% transmission) shall be verified each day prior to testing.

11.3 Gas Analysis. Gas analyzers shall be calibrated daily prior to testing, in accordance with ASTM E800-88, Standard Guide for Measurement of Gases Present or Generated During Fires.

## 12.0 TEST PROCEDURE

The test procedure shall consist of the following:

12.1 Establish an initial volumetric flow rate of at least 0.47 m<sup>3</sup>/sec (1000 ft<sup>3</sup>/min.) through the duct and increase the volume flow rate of 3.4 m<sup>3</sup>/sec (7000 ft<sup>3</sup>/min.) as required to keep the oxygen content above 14 percent and to capture all effluents from the fire room.

12.2 Turn on all sampling and recording devices and take measurements a minimum of once every six seconds. Establish steady-state baseline readings for a minimum of one minute prior to starting a test.

12.3 Ignite the gas burner and simultaneously start the clock and increase flow rate to provide a rate of heat release of 40 kW ± 1 kW (38 Btu/s ± 1 Btu/s) by the burner. Continue the exposure at the 40 kW ± 1 kW (38 Btu/s ± 1 Btu/s) level for 5 minutes. Within 10 sec following the 5 minute exposure, increase the gas flow to provide a rate of heat release by the burner of 150 kW ± 5 kW (142 Btu/s ± 1 Btu/s) exposure for 10 minutes.

12.4 Take 35-mm color photographs at approximately 30 second intervals, or provide a continuous video recording to document the growth of the fire.

12.5 Provide a voice or written record of the fire, which documents the times of all significant events, such as time of ignition, escape of flames through the door way, flashover, etc.

12.6 The ignition burner shall be shut off 15 minutes after start of the test and the test terminated at that time, unless safety considerations dictate an earlier termination.

12.7 Document damage after the test, using words, pictures, and drawings.

## 13.0 CALCULATIONS

13.1 Heat Release. The calculation methods to determine the gross (total) rate of heat release (burner and specimen) shall be as follows:

Calculate mass flow rate using (Equation 1):

$$m_e = C * (\Delta p / T_e)^{1/2} \quad (1)$$

13.1.1 If only O<sub>2</sub> concentration measurements are used.

Calculate the mass flow rate according to the equations 1, and the oxygen depletion factor according to equation 2:

$$\Phi = \frac{X_{O_2}^{Ao} - X_{O_2}^A}{[1 - X_{O_2}^A] * X_{O_2}^{Ao}} \quad (2)$$

Then calculate the rate of heat release (q) according to equation 3:

$$q = E * \frac{M_{O_2}}{M_a} * \frac{\Phi}{1 + \Phi * (\alpha - 1)} * m_e * X_{O_2}^{Ao} \quad (3)$$

If only O<sub>2</sub> is measured, equation 3 simplifies to equation 4:

$$q = E * 1.10 * C * \sqrt{\frac{\Delta p}{T_e}} * \left[ \frac{X_{O_2}^{Ao} - X_{O_2}^A}{1.105 - 1.5 * X_{O_2}^A} \right] \quad (4)$$

13.1.2 If only O<sub>2</sub> and CO<sub>2</sub> concentration measurements are used. Calculate the mass flow rate according to the equations 1 or 2 and the oxygen depletion factor according to equation 5:

$$\Phi = \frac{X_{O_2}^{Ao} * [1 - X_{CO_2}^A] - X_{O_2}^A * [1 - X_{CO_2}^{Ao}]}{X_{O_2}^{Ao} * [1 - X_{O_2}^A - X_{CO_2}^A]} \quad (5)$$

and the rate of heat release according to the same equation 3.

13.1.3 If O<sub>2</sub> and CO<sub>2</sub> and CO concentration measurements are used: Calculate the mass flow rate according to the equations 1 or 2, the moisture content of the incoming atmosphere according to the equation 5 and the oxygen depletion factor according to equation 6:

$$\Phi = \frac{X_{O_2}^{Ao} * [1 - X_{CO_2}^A - X_{CO}^A] - X_{O_2}^A * [1 - X_{CO_2}^{Ao}]}{X_{O_2}^{Ao} * [1 - X_{O_2}^A - X_{CO_2}^A - X_{CO}^A]} \quad (6)$$

Finally calculate the rate of heat release according to equation 7.

$$q = [E * \Phi - [E_{CO} - E]] * \frac{1 - \Phi}{2} * \frac{X_{CO}^A}{X_{O_2}^A} * \frac{M_{O_2}}{M_e} * \frac{m_e}{1 + \Phi * (\alpha - 1)} * X_{O_2}^{Ao} \quad (7)$$

13.2 Smoke Release Rate. Smoke measurement calculation methods shall be as follows:

Optical density (OD) (Equation 8):

$$OD = \log [I_o / I] \quad (8)$$

The volumetric flow rate is calculated as the product of the mass flow rate and the density of air, at the corresponding temperature. Both the volumetric flow and the density of air shall undergo temperature corrections. The volumetric duct flow rate (V) is adjusted because it is measured in the exhaust duct, but required at the temperature near the photodetector, as shown in Equation 9:

$$V_s = V_e * \left( \frac{T_s}{T_e} \right) \quad (9)$$

The density of air is adjusted between the literature value, measured at 273.15 K, and the value at the temperature in the exhaust duct, as shown in Equation 10:

$$\rho = \rho_o * 273.15 / T_e \quad (10)$$

Then the final equation for the volumetric flow rate is equation 11:

$$V_s = (m_e / \rho_o) * (T_o / 273.15) \quad (11)$$

Rate of smoke release (RSR) is defined by equation 12:

$$RSR = V_s * OD * 1/L_p \quad (12)$$

Total smoke released (TSR) is defined by equation 13:

$$TSR = \int RSR dt \quad (13)$$

13.3 Symbols:

A: cross sectional area of duct (m<sup>2</sup>)

C: orifice plate coefficient (kg<sup>1/2</sup> m<sup>1/2</sup> K<sup>1/2</sup>)

E<sub>ts</sub>: net heat released for complete combustion of test specimens per unit of oxygen consumed (13,100 kJ/kg O<sub>2</sub>)

E<sub>p</sub>: net heat released for complete combustion of propane per unit of oxygen consumed (12,800 kJ/kg O<sub>2</sub>)

$E_m$ : net heat released for complete combustion of methane per unit of oxygen consumed (12,500 kJ/kg  $O_2$ )

$E_{CO}$ : net heat released for complete combustion per unit of oxygen consumed, for CO (17,600 kJ/kg  $O_2$ )

$f(R_e)$ : Reynolds number correction (non dimensional)

$I$ : light intensity for a parallel light beam having traversed a certain length of smoky environment and reaching photodetector (non dimensional)

$I_o$ : light intensity for a beam of parallel light rays, measured in a smoke-free environment, with a detector having the same spectral sensitivity as the human eye and reaching the photodetector (non dimensional)

$k_c$ : velocity profile shape factor (non dimensional)

$L_p$ : light path length of beam through smoke environment (m)

$m_e = C(\Delta p/T_e)^{1/2}$  (mass flow rate, by measurement of pressure drop, in kg/s, according to equation 1)

$M_a$ : molecular weight of incoming and exhaust air (29 kg/kmol)

$M_{CO}$ : molecular weight of carbon monoxide (28 kg/kmol)

$M_{CO_2}$ : molecular weight of carbon dioxide (44 kg/kmol)

$M_{H_2O}$ : molecular weight of water (18 kg/kmol)

$M_{N_2}$ : molecular weight of nitrogen (28 kg/kmol)

$M_{O_2}$ : molecular weight of oxygen (32 kg/kmol)

OD: optical density (non dimensional)

$\Delta p$ : pressure drop across the orifice plate or bidirectional probe (Pa)

$q$ : rate of heat release (kW)

RSR: rate of smoke release ( $m^2/s$ )

$T_e$ : combustion gas temperature at the orifice plate (K)

$T_s$ : combustion gas temperature (near photodetector) (K)

TSR: total smoke released ( $m^2$ )

$V_e$ : volumetric flow rate in exhaust duct (at measuring location of mass flow rate) ( $m^3/s$ )

$V_s$ : volumetric flow rate at location of smoke meter (value adjusted for smoke measurement calculations) ( $m^3/s$ )

$X_{CO_2}^A$ : measured mole fraction of  $CO_2$  in exhaust flow (non dimensional)

$X_{CO}^A$ : measured mole fraction of CO in exhaust flow (non dimensional)

$X_{CO_2}^{Ao}$ : measured mole fraction of  $CO_2$  in incoming air (non dimensional)

$X_{O_2}^A$ : measured mole fraction of  $O_2$  in exhaust flow (non dimensional)

$X_{O_2}^{Ao}$ : measured mole fraction of  $O_2$  in incoming air (non dimensional)

$\alpha_{ts}$ : combustion expansion factor for test specimens (non dimensional; normally a value of 1.105)

$\alpha_p$ : combustion expansion factor for propane (non dimensional; normally a value of 1.084)

$\alpha_m$ : combustion expansion factor for methane (non dimensional; normally a value of 1.105)

$\rho$ : density of air at the temperature in exhaust duct ( $kg/m^3$ )

$\rho_o$ : density of air at 273.15 K ( $1.293 kg/m^3$ )

$\Phi$ : oxygen depletion factor (non dimensional)

## 14.0 TEST REPORT:

The test report shall include the following:

14.1 Name and address of testing laboratory

14.2 Date and identification number of the report

14.3 Name and address of the test sponsor

14.4 Materials:

14.4.1 Product description. Identification of the product; foam plastic thickness, type, and density; door facing materials, type and thickness; all other details of door construction necessary to accurately describe the product being tested.

14.4.2 Product mounting details, including the height of the door tested.

14.4.3 Product conditioning and time between removal of the specimen from the conditioning room and the start of testing.

14.4.4 Relative humidity and temperature of the room and the test building prior to, and during, the test.

14.5 Burner Gas Flow. The burner gas flow is the fuel gas flow to the ignition burner and its calculated rate of heat output.

14.6 Time History of the Total Heat Flux to Floor. The time history of the total heat flux to floor is the total incident heat flux at the center of the floor for the heat flux gauge as a function of time starting a minimum of one minute prior to the test.

14.7 Time History of the Gas Temperature. The time history of the gas temperature is the temperature of gases in the room, in the doorway, and in the exhaust duct for each thermocouple; as a function of time starting a minimum of one minute prior to the test.

14.8 Time History of the Total Rate of Heat Production of the Fire, Including Burner Output and Specimen Burning. The total rate of heat production is calculated from the measured oxygen and carbon monoxide concentrations or measured oxygen, carbon monoxide, and carbon dioxide concentrations and the temperature and volumetric flow rate of the gas in the duct.

14.9 Time History of the Net Rate of Heat Release from Burning of the Test Specimen. The net rate of heat release is calculated by subtracting the burner output from the total rate of heat production computed in accordance with Paragraph 14.8 above.

14.10 Time History of the Smoke Release Rate. The time history of the smoke release rate is calculated from the measured reduction in light transmission in the exhaust duct as a function of time, starting a minimum of one minute prior to the test.

14.11 Time History of the Specimen Core Temperature. The time history of the specimen core temperature is the temperature measured by the thermocouple in the specimen foam core as specified

in 26.810.2(5), as a function of time starting a minimum of one minute prior to test.

14.12 Time History of the Fire Growth. The time history of the fire growth is a transcription of the visual, photographic, audio, and written records of the fire test. The records shall indicate the time of ignition of the test specimen, the approximate location of the flame front most distant from the ignition source at approximately 30 second intervals during the fire test and, if they occur, the time of flashover, and the time at which flames extend outside the doorway. In addition, still photographs taken at approximately 30 second intervals or continuous video recording shall be supplied.

14.13 Drawings and photographs or video recording shall be supplied to show the extent of the damage of the materials after the test.

14.14 Table of numerical results containing the following:

14.14.1 Peak total rate of heat release (kW), and the time at which it occurred

14.14.2 Peak net (specimen only) rate of heat release (kW), and the time at which it occurred

14.14.3 Total heat released (MJ)

14.14.4 Maximum heat flux at floor level (kW/m<sup>2</sup>), and the time at which it occurred

14.14.5 Peak rate of smoke release (m<sup>2</sup>/s), and the time at which it occurred

14.14.6 Total smoke released (m<sup>2</sup>)

14.14.7 Total smoke released at 5 min. and at 7.5 min. (m<sup>2</sup>)

14.14.8 Peak specimen core temperature and the time at which it occurred

14.14.9 Peak fire room temperatures (°Celsius) and the time at which they occurred

14.14.10 Equation used to calculate rate of heat release

## 15.0 ACCEPTANCE CRITERIA

Foam plastic insulated garage doors shall be considered as demonstrating satisfactory performance if the following conditions are met:

15.1 The maximum instantaneous net peak rate of heat release of the test sample shall not exceed 250 kW (237 Btu/s).

15.2 Flames shall not propagate for the full width of the test specimen. Propagation for the full width of the specimen shall be judged to occur:

If flames are visually observed to spread for the full width of the specimen, or

If the test specimen core temperature rise, determined by the thermocouple specified in 10.2.5 exceeds 400°C (750°F).

15.3 The total smoke released shall not exceed 60 m<sup>2</sup> (670 ft<sup>2</sup>) 5 minutes after the start of the test, nor shall the total smoke release exceed 150 m<sup>2</sup> (1670 ft<sup>2</sup>) 7.5 minutes after the start of the test.



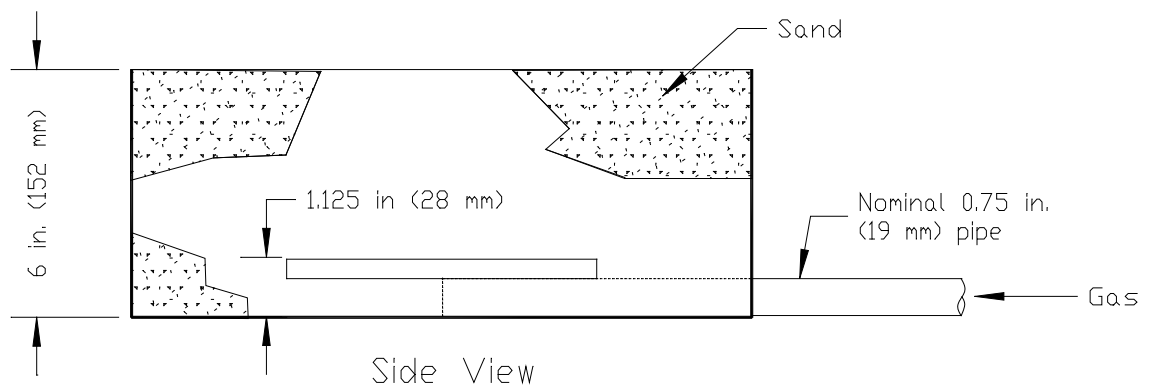
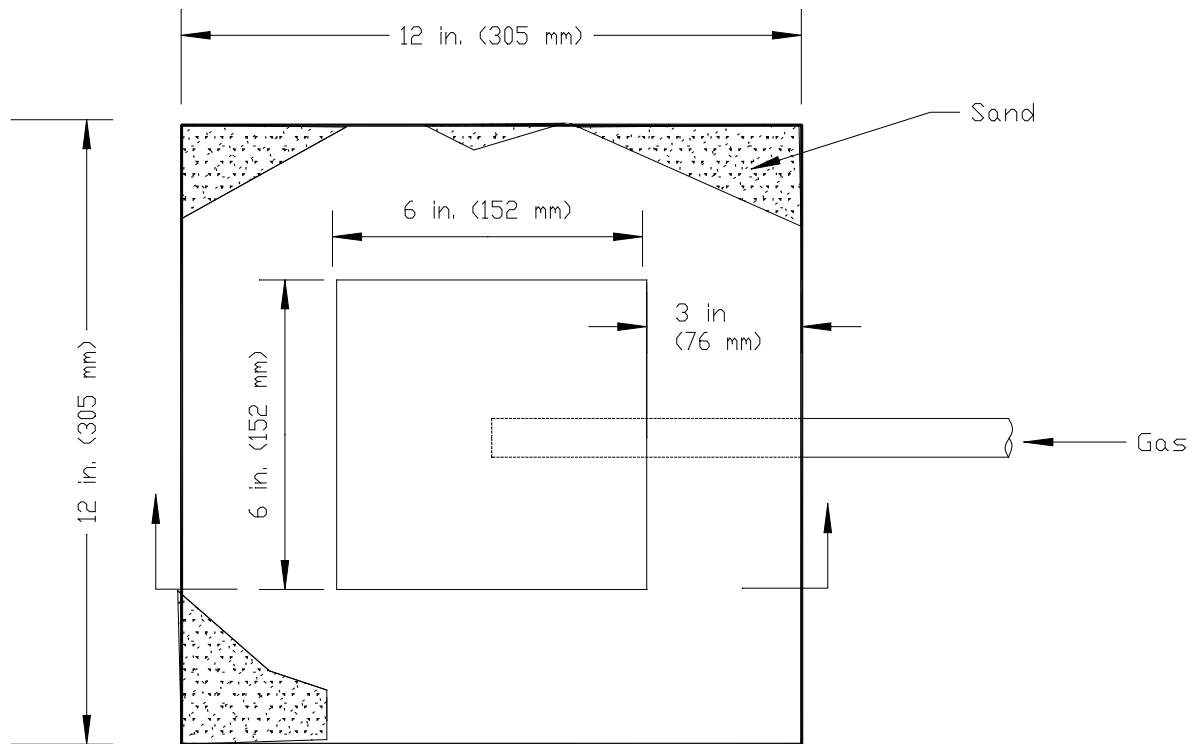

Figure No. 1 - Gas Burner

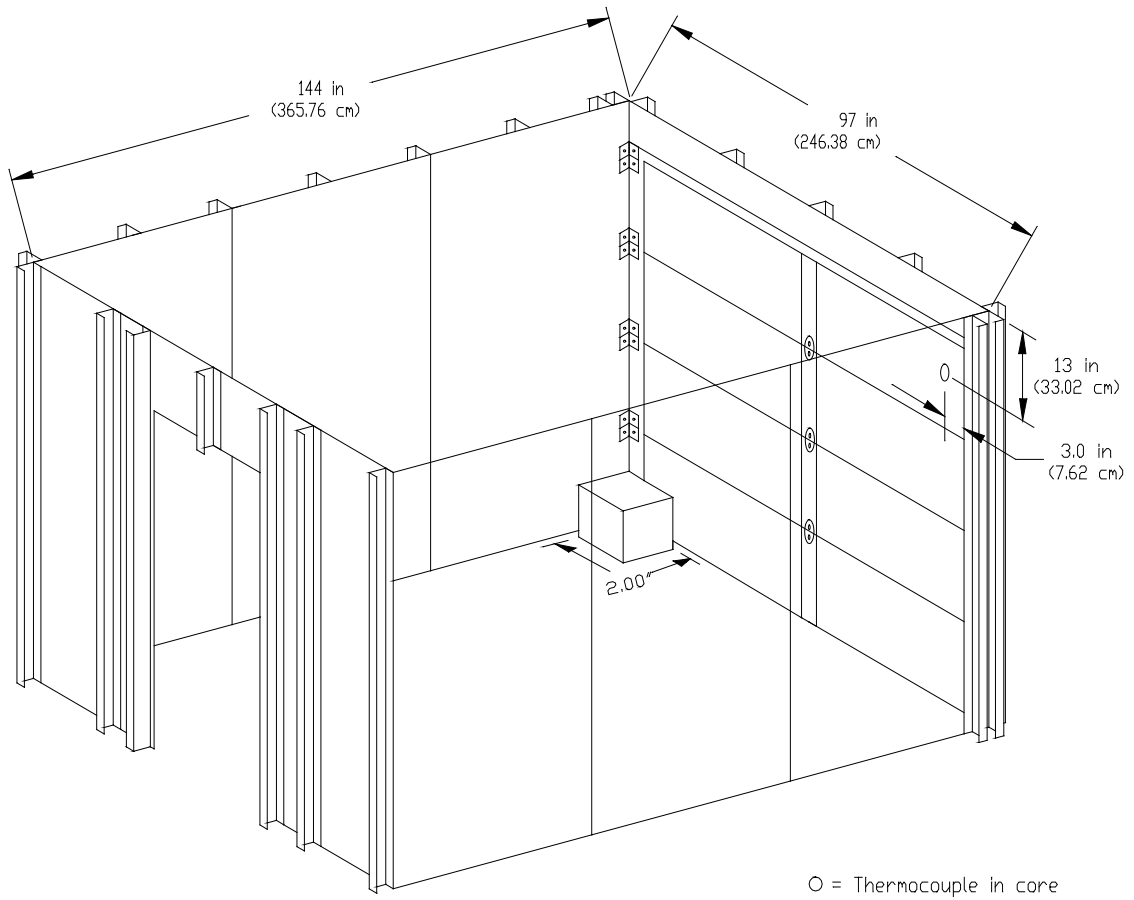
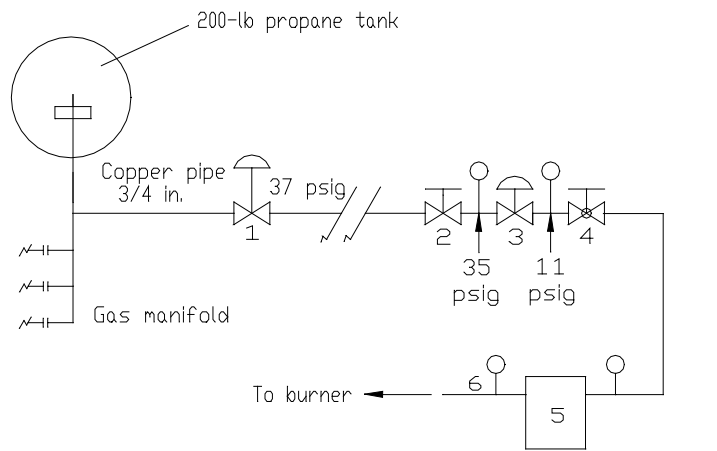
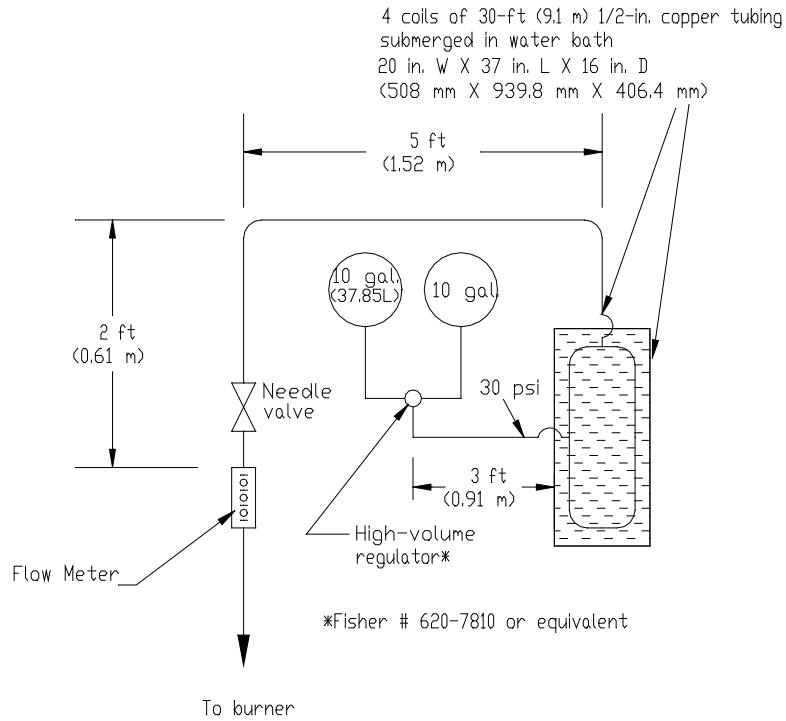

Figure No. 2 - Burner Location and Specimen Mounting Details



- 1 - Propane gas regulator (high pressure) (main gas supply)
  - 2 - Shutoff valve
  - 3 - Regulator (low pressure)
  - 4 - Adjustable valve for flow impedance
  - 5 - Volume meter
  - 6 - Steel braid over tubing to burner
- Line pressures are shown

Figure No. 3 - Gas Flow Regulation Systems

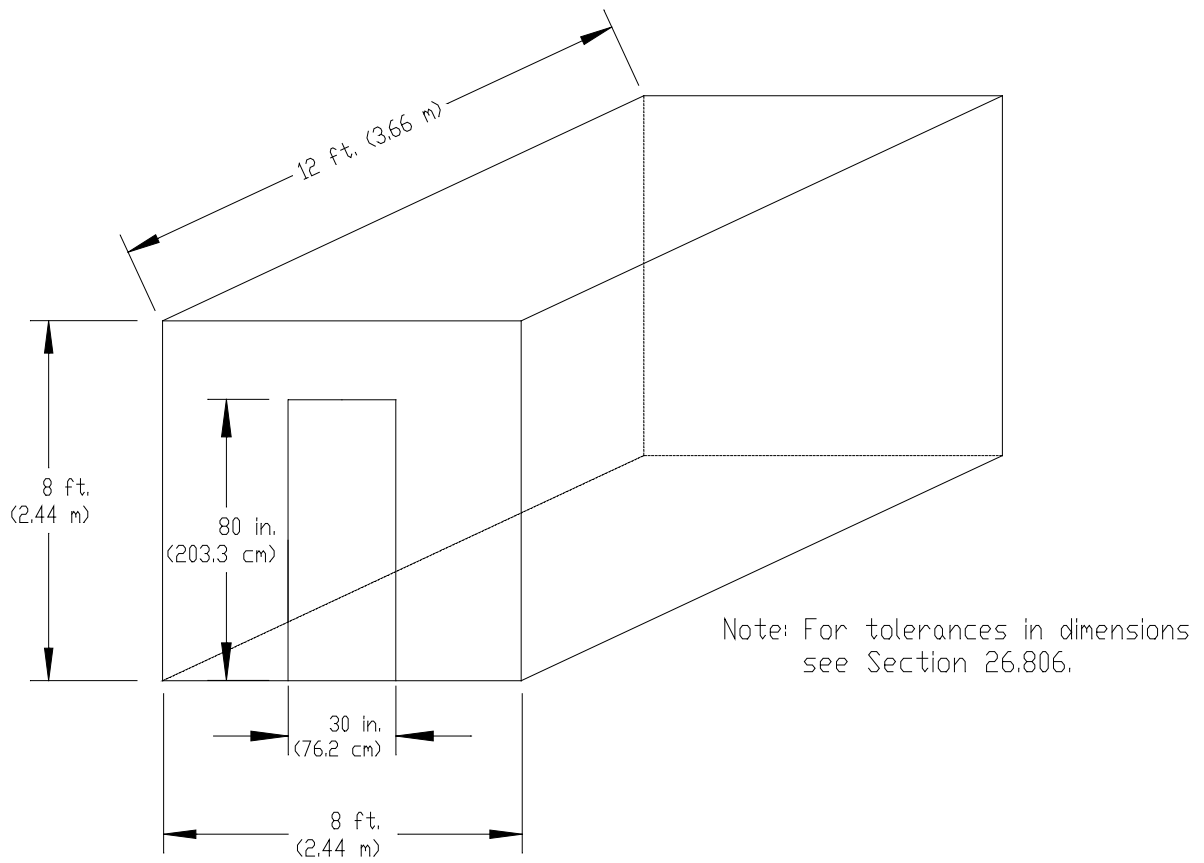

Figure No. 4 - Interior Room & Doorway Dimensions

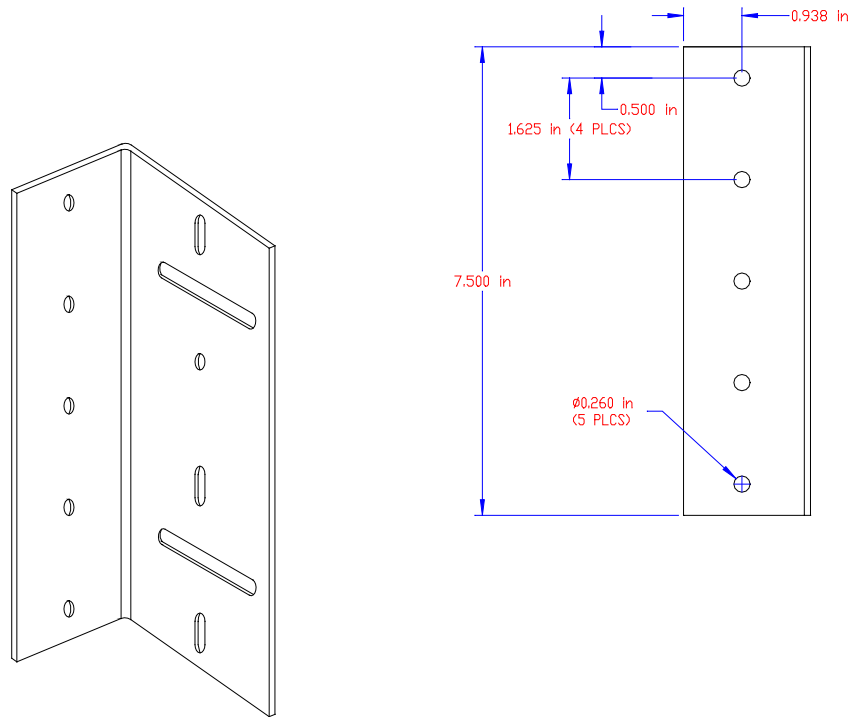
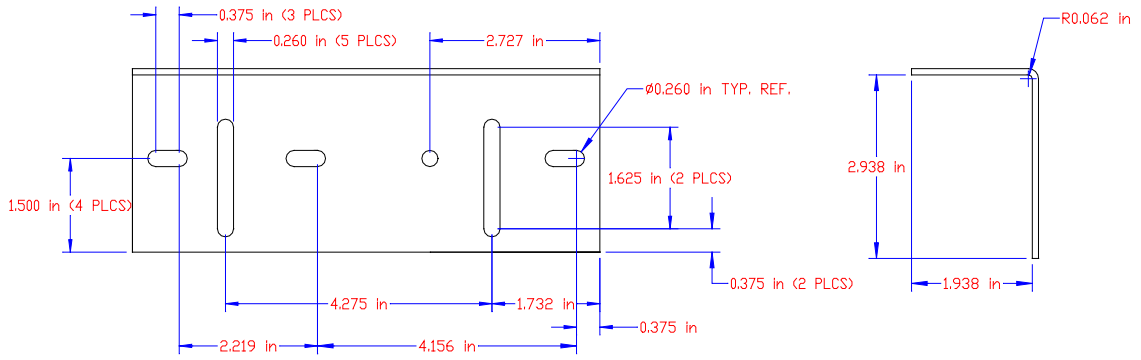
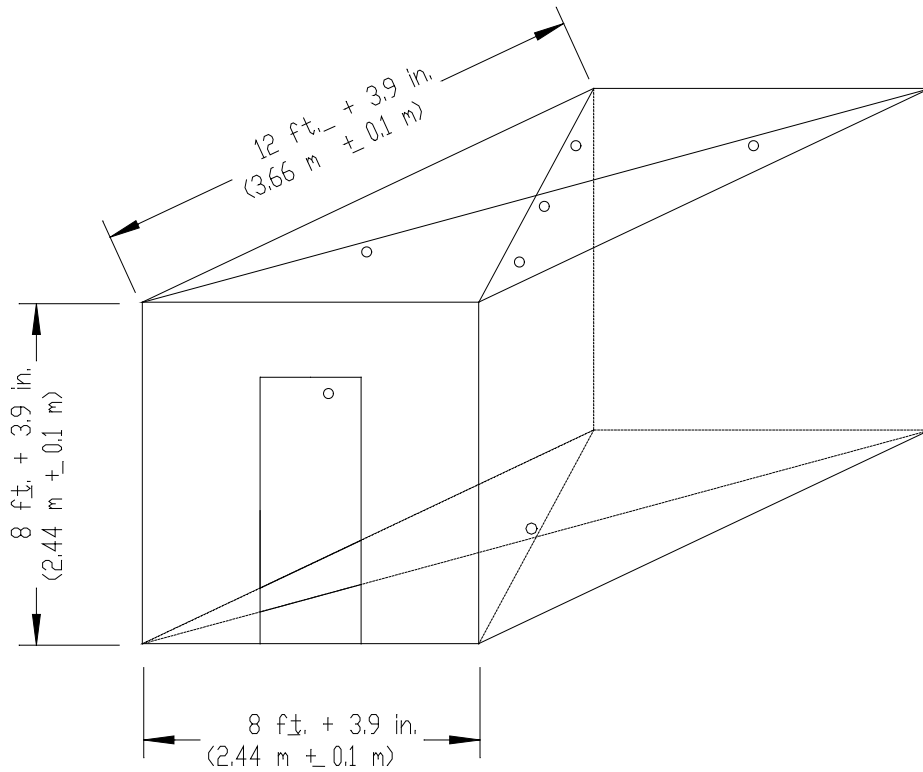

Figure No. 5 - Angle Brackets



○ = Thermocouples - Each 4 in. (102 mm) below ceiling. Also one additional thermocouple over the burner and 4 in. (102 mm) below the ceiling.

○ = Calorimeter on floor - 2 in. (51 mm) above floor.

Figure No. 6 - Thermocouple and Calorimeter Placement

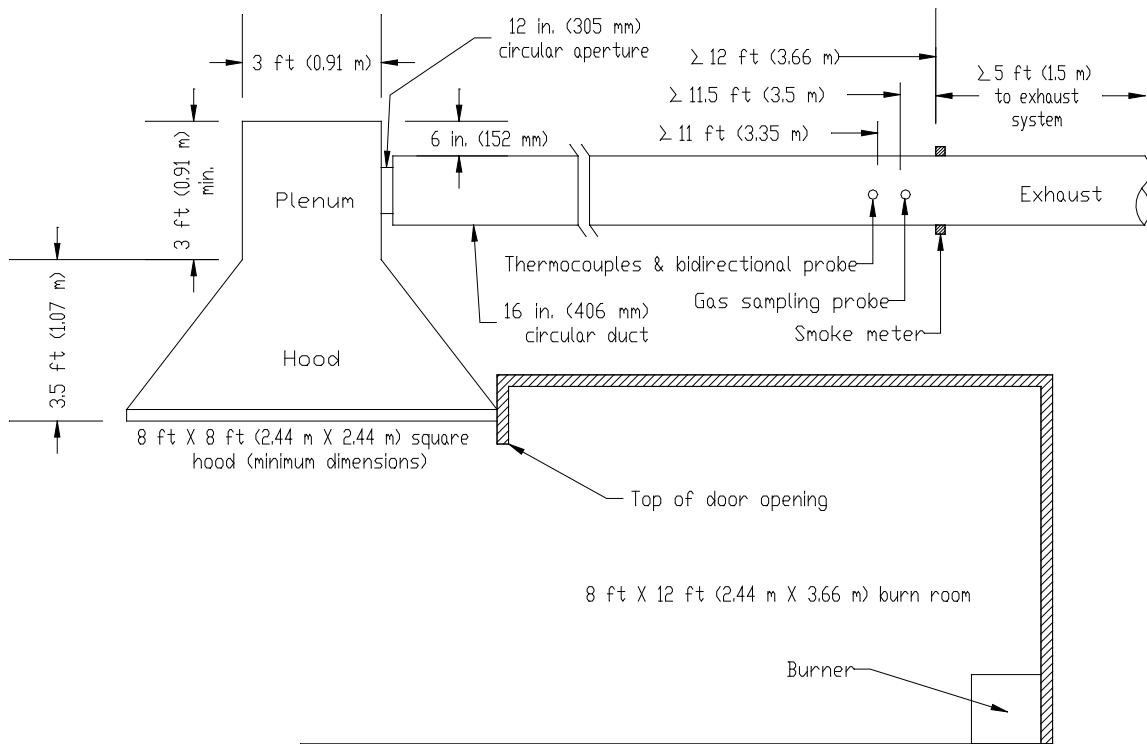

Note: Duct instrumentation locations are minimum for 16 inch duct.

Figure No. 7 - Canopy Hood and Exhaust Duct

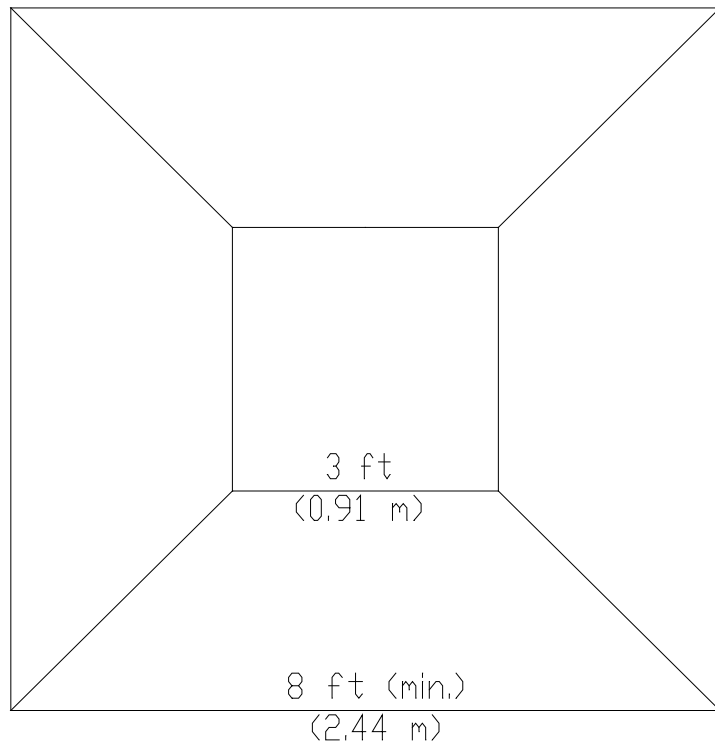

Figure No. 8 - Plan View of Canopy Hood



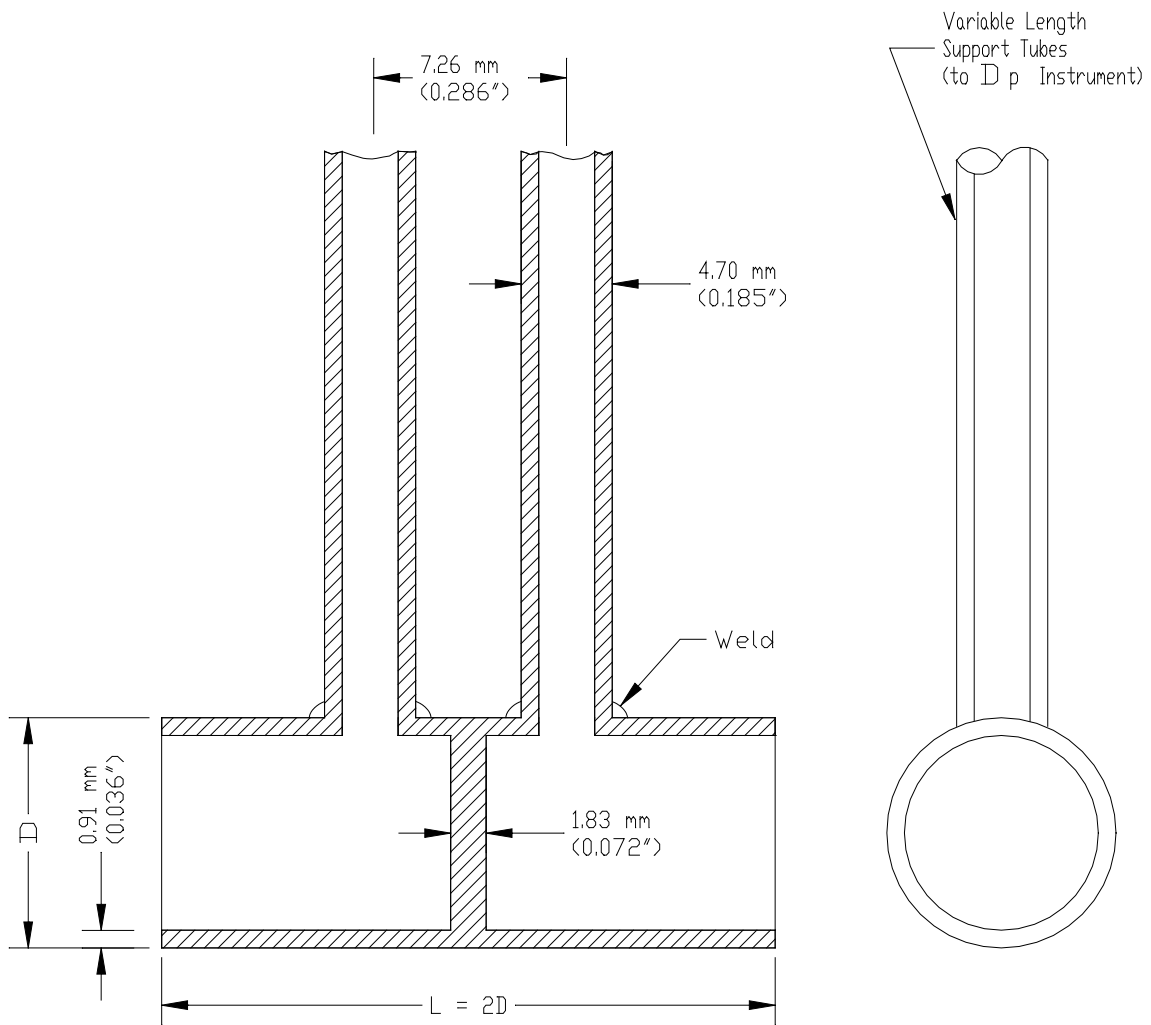

Figure No. 9 - Bidirectional Probe

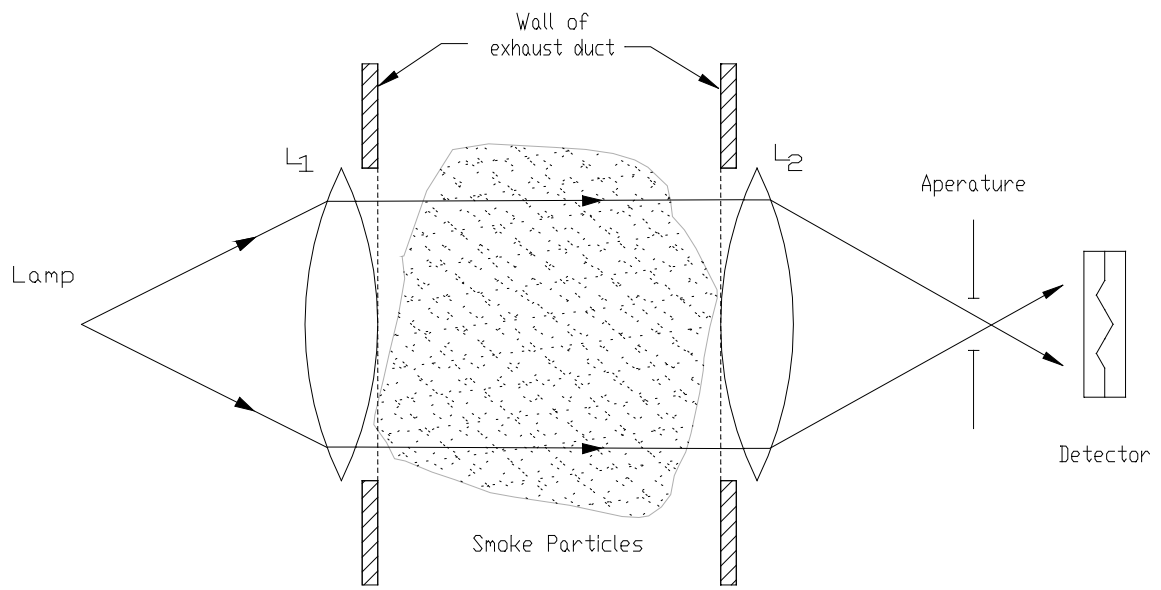
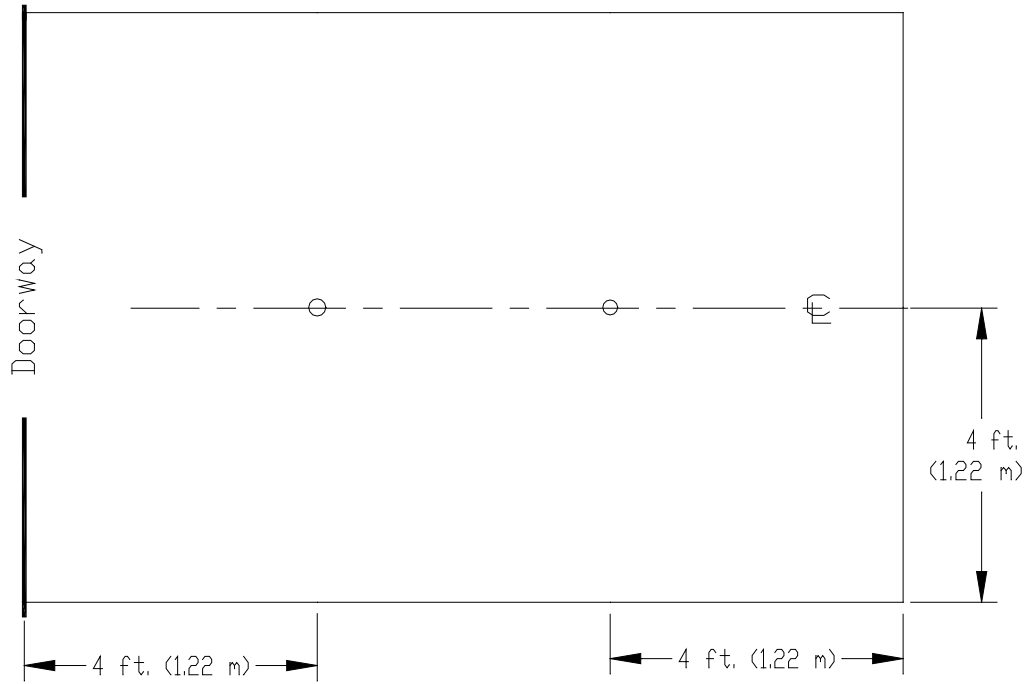

Figure No. 10 - Optical System, Using a White Light



○ = Paper Target

Figure No. 11 - Paper Target Arrangement - Plan View



**DASMA** – the Door & Access Systems Manufacturers Association, International – is North America’s leading trade association of manufacturers of garage doors, rolling doors, garage door operators, vehicular gate operators, and access control products. With association headquarters based in Cleveland, Ohio, our 90 member companies manufacture products sold in virtually every county in America, in every U.S. state, every Canadian province, and in more than 50 countries worldwide. DASMA members’ products represent more than 95% of the U.S. market for our industry.

For more information about the Door & Access Systems Manufacturers Association, International, contact:

**DASMA**  
1300 Sumner Avenue  
Cleveland, OH 44115-2851  
Phn: 216/241-7333  
Fax: 216/241-0105  
E-Mail: [dasma@dasma.com](mailto:dasma@dasma.com)  
URL: [www.dasma.com](http://www.dasma.com)