



1300 Sumner Avenue
Cleveland, Ohio 44115-2851
Phone: 216-241-7333 • Fax: 216-241-0105
E-mail: dasma@dasma.com

Common Jamb Construction for Rolling Counter Fire Doors: Non-Masonry Construction – Bolted Guides

Introduction

Rolling counter fire doors are tested for compliance with recognized standards such as UL 10B and NFPA 252. When tested, these doors are mounted on frames with jambs intended to replicate field construction. The test frame is held on the face of the test furnace for a specified period of time. The guides must remain fastened to the jambs and no “through gaps” may occur in the door assembly during the test. This DASMA Technical Data Sheet includes a representation of jamb construction and guide attachment details. Guide configurations and approved jamb construction will vary with individual fire door manufacturer's listings. Consult with individual manufacturers for specific guide details and jamb constructions for which they are approved.

Objectives

The objectives of preparing the enclosed set of standard details are:

1. To show how counter fire door guide assemblies are located on the jambs for face-of-the-wall mounting and between-the-jambs mounting.
2. To help architects, engineers and others involved with building specifications understand the relationship between the rolling counter fire door guides and the jamb/wall design.
3. To have the attached details included in applicable reference documents used by architects, engineers, specifiers and code officials.

Attachment Contents

- Figure 1: Between-the-jambs mounted counter fire door guide configuration; unexposed double steel stud at jamb.
- Figure 2: Face-of-the-wall mounted counter fire door guide configuration; unexposed double steel stud at jamb.
- Figure 3: Between-the-jambs mounted counter fire door guide configuration; unexposed steel tube and stud at jamb.
- Figure 4: Face-of-the-wall mounted counter fire door guide configuration; unexposed steel tube and stud at jamb.

Note: Technical Data Sheets are information tools only and should not be used as substitutes for instructions from individual manufacturers. Always consult with individual manufacturers for specific recommendations for their products and check the applicable local regulations.

This Technical Data Sheet was prepared by the members of DASMA's Rolling Door Division Technical Committee. DASMA is a trade association comprising manufacturers of rolling doors, fire doors, grilles, counter shutters, sheet doors, and related products; upward-acting residential and commercial garage doors; operating devices for garage doors and gates, sensing devices, and electronic remote controls for garage doors and gate operators; as well as companies that manufacture or supply either raw materials or significant components used in the manufacture and installation of the Active Members' products.

DASMA Recommended

Common Jamb Construction:

Rolling Counter Fire Doors on Non-Masonry Walls

Bolted Guides

General Notes:

1. Existing and new wall construction covered
2. Details are for general information only
3. Details are based on UL Classified and FM Approved Products
4. Consult a structural engineer for actual wall construction
5. Details are attachments to TDS-264

Note: Technical Data Sheets are information tools only and should not be used as substitutes for instructions from individual manufacturers. Always consult with individual manufacturers for specific recommendations for their products and check the applicable local regulations.

This Technical Data Sheet was prepared by the members of DASMA's Rolling Door Division Technical Committee. DASMA is a trade association comprising manufacturers of rolling doors, fire doors, grilles, counter shutters, sheet doors, and related products; upward-acting residential and commercial garage doors; operating devices for garage doors and gates, sensing devices, and electronic remote controls for garage doors and gate operators; as well as companies that manufacture or supply either raw materials or significant components used in the manufacture and installation of the Active Members' products.

DASMA Recommended Common Jamb Construction for Rolling Counter Fire Doors For Maximum 1 1/2 Hour Rating

Note: Thickness and number of layers of gypsum board determined by wall rating

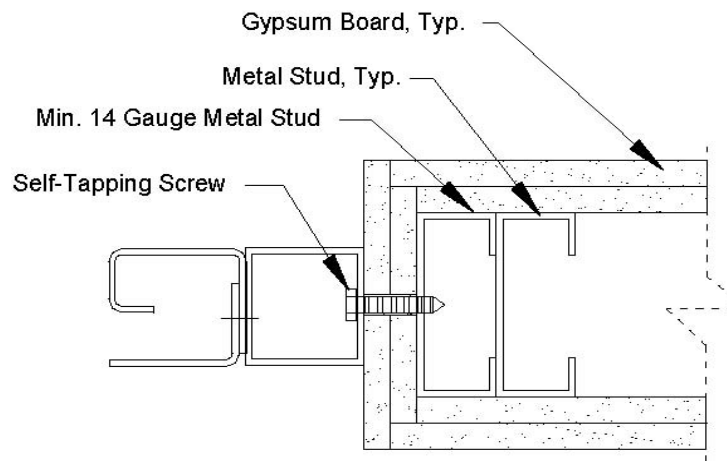

Figure 1

Between-the-jambs mounted
counter fire door guide configuration;
unexposed double steel stud at jamb

Note: Technical Data Sheets are information tools only and should not be used as substitutes for instructions from individual manufacturers. Always consult with individual manufacturers for specific recommendations for their products and check the applicable local regulations.

This Technical Data Sheet was prepared by the members of DASMA's Rolling Door Division Technical Committee. DASMA is a trade association comprising manufacturers of rolling doors, fire doors, grilles, counter shutters, sheet doors, and related products; upward-acting residential and commercial garage doors; operating devices for garage doors and gates, sensing devices, and electronic remote controls for garage doors and gate operators; as well as companies that manufacture or supply either raw materials or significant components used in the manufacture and installation of the Active Members' products.

**DASMA Recommended
Common Jamb Construction for Rolling Counter Fire Doors
For Maximum 1 1/2 Hour Rating**

Note: Thickness and number of layers of gypsum board determined by wall rating

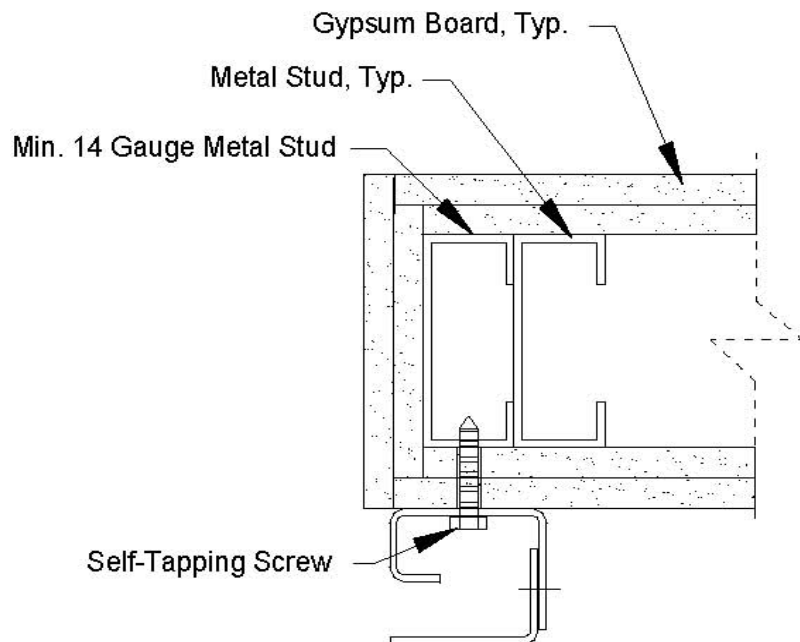

Figure 2

**Face-mounted counter fire door
guide configuration;
unexposed double steel stud at jamb**

Note: Technical Data Sheets are information tools only and should not be used as substitutes for instructions from individual manufacturers. Always consult with individual manufacturers for specific recommendations for their products and check the applicable local regulations.

This Technical Data Sheet was prepared by the members of DASMA's Rolling Door Division Technical Committee. DASMA is a trade association comprising manufacturers of rolling doors, fire doors, grilles, counter shutters, sheet doors, and related products; upward-acting residential and commercial garage doors; operating devices for garage doors and gates, sensing devices, and electronic remote controls for garage doors and gate operators; as well as companies that manufacture or supply either raw materials or significant components used in the manufacture and installation of the Active Members' products.

DASMA Recommended Common Jamb Construction for Rolling Counter Fire Doors For Maximum 1 1/2 Hour Rating

Note: Thickness and number of layers of gypsum board determined by wall rating

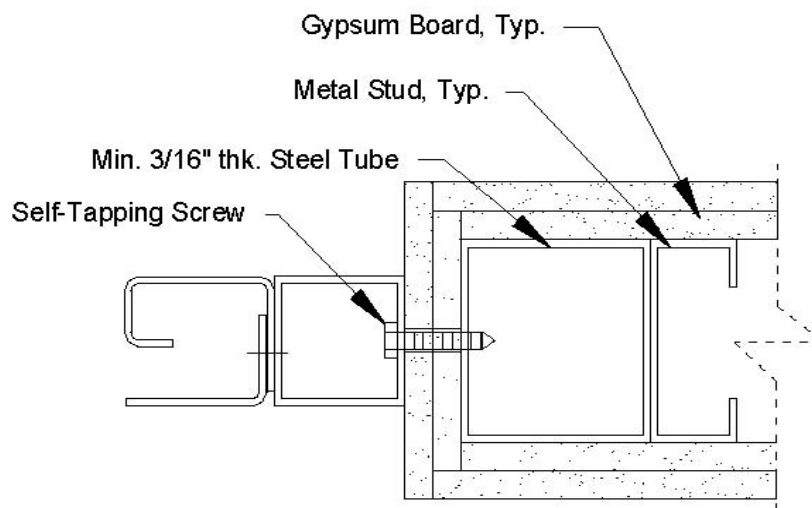

Figure 3
**Jamb-mounted counter fire door
guide configuration;
unexposed steel tube and stud at jamb**

Note: Technical Data Sheets are information tools only and should not be used as substitutes for instructions from individual manufacturers. Always consult with individual manufacturers for specific recommendations for their products and check the applicable local regulations.

This Technical Data Sheet was prepared by the members of DASMA's Rolling Door Division Technical Committee. DASMA is a trade association comprising manufacturers of rolling doors, fire doors, grilles, counter shutters, sheet doors, and related products; upward-acting residential and commercial garage doors; operating devices for garage doors and gates, sensing devices, and electronic remote controls for garage doors and gate operators; as well as companies that manufacture or supply either raw materials or significant components used in the manufacture and installation of the Active Members' products.

DASMA Recommended Common Jamb Construction for Rolling Counter Fire Doors For Maximum 1 1/2 Hour Rating

Note: Thickness and number of layers of gypsum board determined by wall rating

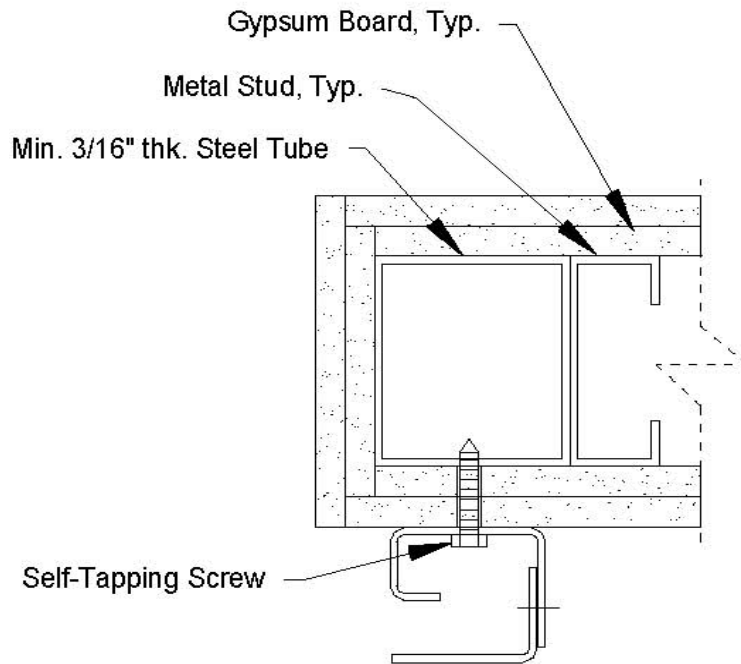

Figure 4
Face-mounted counter fire door
guide configuration;
unexposed steel tube and stud at jamb

Note: Technical Data Sheets are information tools only and should not be used as substitutes for instructions from individual manufacturers. Always consult with individual manufacturers for specific recommendations for their products and check the applicable local regulations.

This Technical Data Sheet was prepared by the members of DASMA's Rolling Door Division Technical Committee. DASMA is a trade association comprising manufacturers of rolling doors, fire doors, grilles, counter shutters, sheet doors, and related products; upward-acting residential and commercial garage doors; operating devices for garage doors and gates, sensing devices, and electronic remote controls for garage doors and gate operators; as well as companies that manufacture or supply either raw materials or significant components used in the manufacture and installation of the Active Members' products.